

Lab 10: Feedback and Oscillation

U.C. Davis Physics 116A

INTRODUCTION

This lab consists of two parts. Both show some property of feedback. The Wien bridge oscillator illustrates how a feedback amplifier can become an oscillator. The class B output stage experiment shows how negative feedback can reduce distortion.

1. WIEN BRIDGE OSCILLATOR

Here, positive feedback is demonstrated by turning an op amp into an oscillator. The condition for oscillation in a feedback amplifier is discussed in Sec. 10.4 of *Bobrow*. This circuit, the Wien bridge oscillator, is covered in pp. 695-697.

The gain of a feedback amplifier, A_F , is given by

$$A_F = \frac{A}{1 + AB},$$

where A is the amplifier gain and B is the gain of the *feedback network* (assumed to provide *negative* feedback). The loop gain is defined as the product, AB . The amplifier becomes an oscillator (a circuit which produces an output at some frequency with no external input) if $AB = -1$, so that the denominator on the right vanishes.

This property of feedback amplifiers is used in the basic Wien bridge oscillator shown in Fig. 1. We now calculate the oscillation frequency, the frequency at which $AB = -1$.

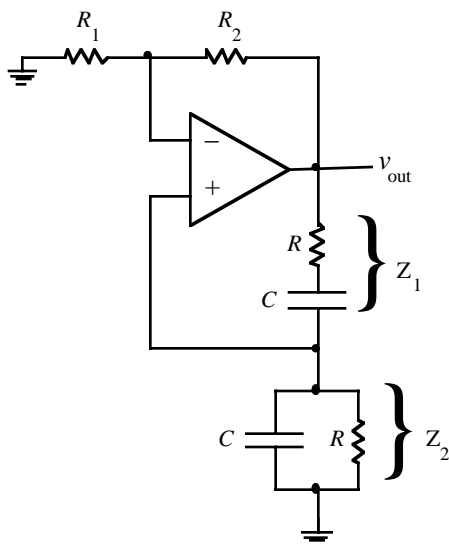

Figure 1: Wien bridge oscillator.

The two resistors R_1 and R_2 determine the gain, $A = 1 + R_2/R_1$, of a noninverting amplifier.

The two complex impedances

$$Z_1 = \frac{1}{j\omega C} + R \quad \text{and} \quad Z_2 = \frac{R \frac{1}{j\omega C}}{R + \frac{1}{j\omega C}}$$

provide positive feedback since they feed back into the + input. To be consistent with our formula for A_F (negative feedback), we need a minus sign in the expression for B (positive feedback means B is negative):

$$B = B(j\omega) = -\frac{Z_2}{Z_1 + Z_2}.$$

To have an oscillator, $AB = -1$. This puts conditions on R , C and ω and on A . For your report, prove

$$B = \frac{-\omega RC}{3\omega RC - j(1 - \omega^2 R^2 C^2)}.$$

For $AB = -1$, we need $\omega = 1/RC$ (since the imaginary part of the result is zero) so $B = -1/3$.

Thus we choose R_1 and R_2 so that $A = 3$.

Unfortunately, this oscillator will not produce a clean sinusoidal output because the amplitude will build up until the amplifier nonlinear region is reached. We need to introduce additional components to keep the amplitude constant and within in the linear range of the op-amp, as is described on the next page.

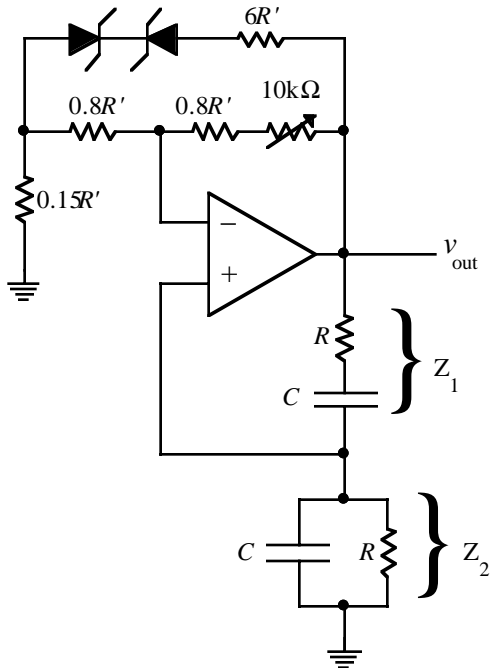

Figure 2: Wien bridge oscillator with controlled amplitude.

We now modify the circuit (as shown in Fig. 2, above) by setting the gain slightly too high and adding another resistor which is connected in parallel with the feedback resistor when some maximum amplitude (set by the two zener diodes) is exceeded. This reduces the gain until the amplitude falls below the Zener threshold again. In this way, the output amplitude remains fairly stable near the Zener

threshold. The value of R' is about $6k$ and the intended values of the fractional R 's are:

$$6R' = 33k\Omega$$

$$0.8R' = 4700\Omega$$

$$0.15R' = 1k\Omega$$

Adjust the potentiometer to get different amplitudes of oscillation. Find the frequency and amplitude of the maximum amplitude oscillation. For your lab report, sketch this waveform and measure its frequency. Compare this to the theoretical value.

2. CLASS B OUTPUT STAGE AND REDUCTION OF DISTORTION WITH NEGATIVE FEEDBACK

This section demonstrates a push-pull or class B amplifier. It is described in *Bobrow*, pp. 629-635. The purpose of such an amplifier is to get a greater output power while using less power supply power.

Look at the circuit of figure 3. Compare the output waveform with the feedback resistor R_2 connected to points A and v_{out} in the circuit. Note the very obvious "crossover distortion" in the A configuration and the much improved output in the v_{out} configuration. Try to qualitatively explain why the first configuration has this distortion and why it is improved by the second configuration.

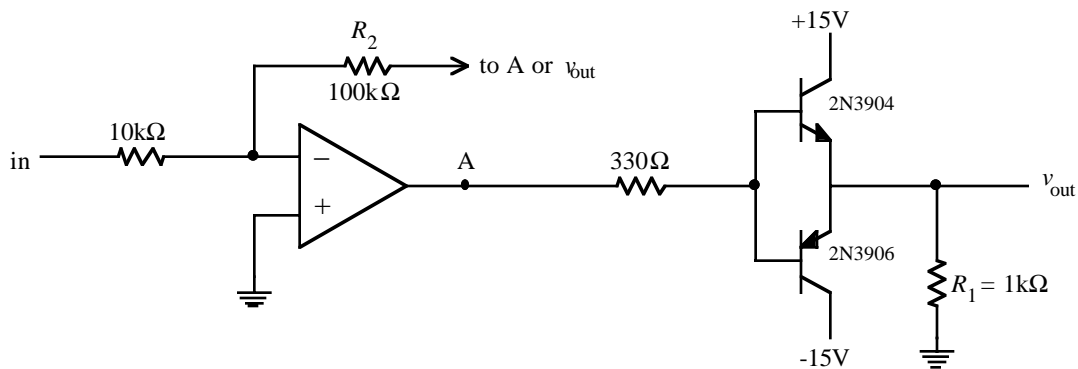

Figure 3: Inverting amplifier with class B output stage. Connect R_2 to v_{out} to observe the effect of negative feedback in reducing distortion.